

# Muto Wide Blower

## Instruction Manual

Read this manual carefully before using the product.

Wrong operations deviating from this manual may lead to serious accidents or damages.

Keep this manual convenient location for easy access.



***Muto Denki Corporation***

Headquarters: 751, Nishi Hassaku-cho, Midori-ku, Yokohama, Kanagawa, Japan 226-0024

TEL: 81-45-932-2211, FAX: 81-45-932-2219

Osaka Branch: 4-14, Toyosaki 3, Kita-ku, Osaka City, Osaka, Japan 531-0072

TEL: 81-6-6372-1100, FAX: 81-6-6372-1797

Chino Plant: 11400-1107, Aza Harayama, Tamagawa, Chino City, Nagano, Japan 391-0011

TEL: 81-266-79-6071, FAX: 81-266-79-6074

web: <http://www.mutodenki.co.jp>

e-mail: [sales@mutodeki.co.jp](mailto:sales@mutodeki.co.jp)

## Table of contents

1. Introduction .....	3
2. Safety precautions .....	4
3. Receiving Checkups .....	5
4. Transportation and Handling .....	5
5. Storage .....	5
6. Installation .....	5
7. Piping .....	6
8. Connection to Power .....	6
9. Test run .....	7
10. Operation .....	9
11. Maintenance and Check .....	9
12. Bearing .....	11
13. Shaft seal .....	12
14. Coupling .....	14
15. Belt .....	18
16. Motor .....	20
17. Inquiry .....	20
18. Limited Warranty .....	20
Appendix-1 Troubleshooting.....	21
Appendix-2 Structural drawing.....	23

## 1. Introduction

Thank you for purchasing the Muto Wide Blower.

This manual contains the information you need for handling, installing, operating and maintaining your new equipment correctly, to ensure trouble-free operation and long service life. Please read it thoroughly. After reading this manual, keep it in convenient place for easy access.

First, confirm the blower's type referring to the following description.

### **S type** (Direct Driven)

Fans are directly mounted on the extended motor shaft.

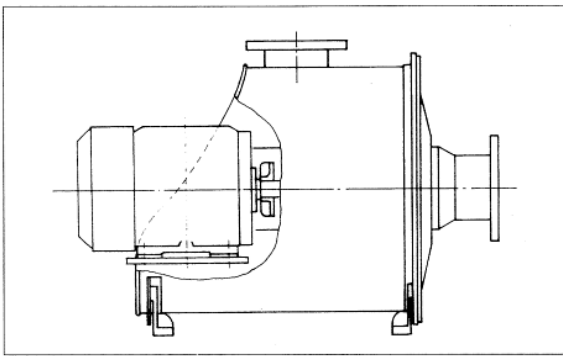

### **H type** (Direct Coupled)

Blower shaft and motor are coupled with flexible coupling.

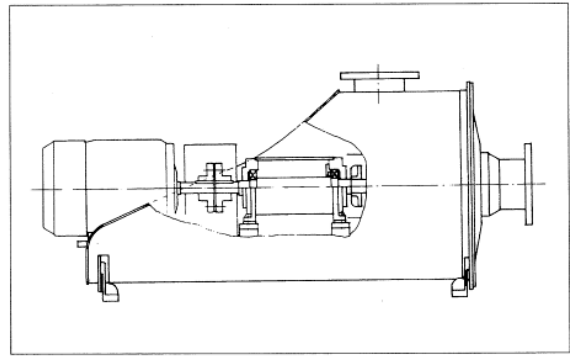

### **HL type** (Horizontal Belt Driven)

Blower and motor are placed side by side on the common base.

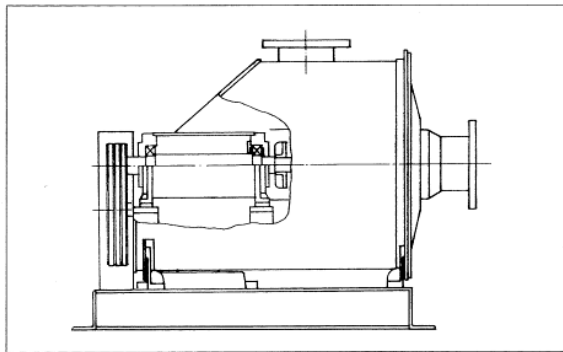

### **HH type** (Vertical Belt Driven)

The motor is mounted on the blower casing.

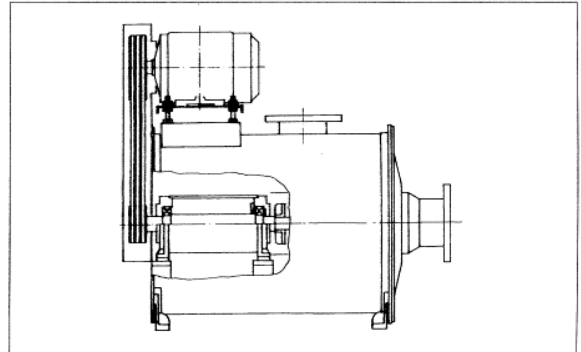

## 2. Safety precautions

Before starting any work such as handling, installing, operating and maintaining, carefully read this manual and all documents attached to the product for proper use. Use the product after thorough understanding of all product information, safety information and precautions.

In this manual, safety precautions are classified as “Warning” and “Caution”.



**Warning**

This tag indicates that wrong operation or use may lead to fatal loss or serious injury.



**Caution**

This tag indicates that wrong operation or use may lead to human injury or loss of property.

Even the items under  may lead to serious results depending on the circumstances. Those precautions include very important information and it is strongly recommended to follow them strictly.

### **Warning**      **Place to install**

The product with non-explosion proof type motor shall not be installed in explosive or inflammable atmospheres. Under those atmospheres, install the product with explosion proof type motor conforming to the degree of danger in that place. Otherwise injuries, explosions or fires may occur.

### **Warning**      **Wiring**

Refer to the instruction manual of motor. Provide grounding to the equipment. Do not touch the wiring. Shut off the power before checking the wiring. Otherwise electrical shocks may occur.

### **Warning**      **Gases to be handled**

Unless otherwise agreed separately, the product can handle only normal air. It cannot be handled any other gas (explosive, toxic, corrosive, high temperature and so on), liquid or solid materials. Otherwise injuries, explosions or fires may occur.

### **Warning**      **Do not get close to the open inlet and outlet**

Do not get close to or look into the open inlet or outlet manifold during the product is running as it is very dangerous as follows.

Inlet : Clothing which you are wearing or a part of your body will be sucked in. As a result, injuries may occur.

Outlet : A strong wind or flown things may cause injuries.

### **Warning**      **Rotating object**

Do not insert finger(s) or hand(s) into the opening of the safety covers such as external fan cover and cooling fan cover. Do not remove the safety cover during the product is running. Otherwise injuries may occur.

## **Caution**      **High heat**

If the product has high temperature label, do not touch the product with body or hand during the product is running. Take safety measures such as enclosing by fence or net. Otherwise burns may occur.

## **Warning**      **Safety components**

The product is shipped with metal mesh attached to the inlet and outlet manifold, or otherwise the optional parts are included. If these parts are removed by some reason, take equivalent safety measures. Otherwise injuries may occur.

### **3. Receiving Checkups**

Check if the products you have received are what have been ordered by referring to the order sheet, drawings, invoices, etc.

- (1) Check the nameplates on the blower and the motor, and confirm if it matches what have been ordered.
- (2) Count the number of the product, and confirm if it agrees with what have been ordered.
- (3) Check that there is no breakage during transportation.

### **4. Transportation and Handling**

When transporting the blower, be careful not to give shocks to any parts of the blower.

### **5. Storage**

If the blower is stored before installation, be careful as follows:

- (1) Store the blower in a room where ventilated, not humid nor dusty. Otherwise the blower may have some troubles.
- (2) Before operating the blower which has been stored for long period of time, check if the bearing and the insulation of the motor have no problem. And carefully check if the blower has no abnormality.
- (3) While the blower is stored, rotate the blower shaft several times by hand every month. If this procedure is not performed, the life of the bearing may become short.

### **6. Installation**

The blower should be placed on a flat and rigid foundation with vibration isolator pads. If there are gaps between the pad and foundation, fill the gaps with thin steel sheets (shimming).

Clear some space to maintain the blower.

When anchor bolts are used, do not fasten nuts tightly so that the pads will be effective.

## 7. Piping

Use rubber sleeves or flexible joints to connect to piping to avoid unnecessary force to the blower and to isolate the vibration from the blower. If direct connection to piping is inevitable, do not give the force to the blower by dimensional tolerances, weight of piping, thermal expansion of piping, etc.

## 8. Connection to Power



**Warning** Connect to power under the instruction by electrical engineer and follow the electric technical standards and instruction manual of the motor.

- (1) Turn the fan by hand to verify free rotation without rubbing or noise.
- (2) Check the nameplates of blower and motor and confirm if they agree with the specification for power supply, then connect to power line under instruction by electrical engineer and per electric technical standards and wiring regulation.

## 9. Test run

Although the blower is properly tested by us, conduct the test run referring to the flowchart “9-1”

### 9-1. Test run flowchart

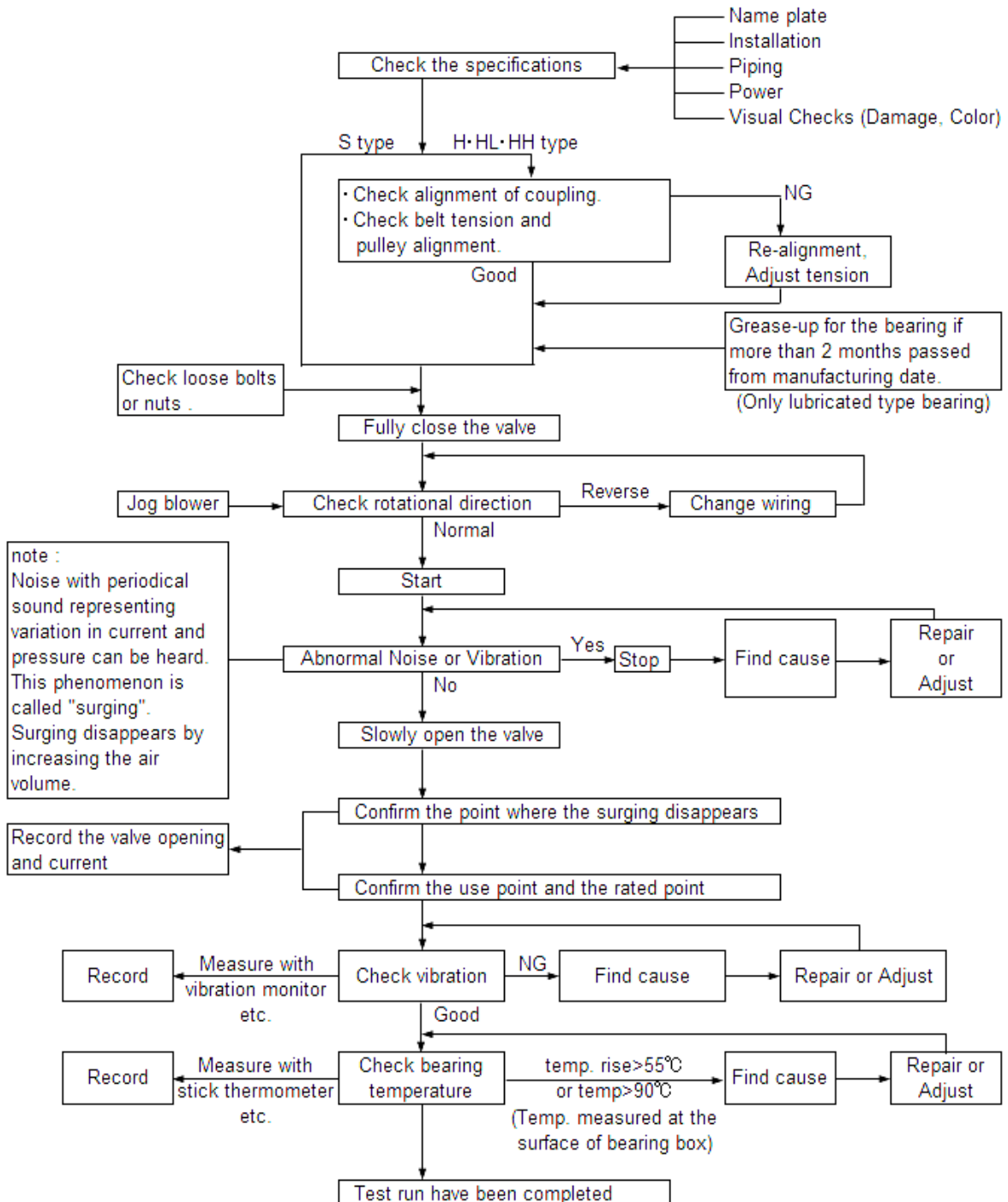

### 9-2. Notes

Following are the cautions and additional explanations.

#### (1) Specifications

Before the test run, check the specifications and confirm there is no false.

- a) Check ordered specifications with the name plate on the blower.
- b) Check condition of the installation.

- c) Check condition of the piping.
  - d) Check power and name plate on the motor.
  - e) Visually check the blower.
- (2) Alignment
- a) Alignment of coupling (H type)  
Make sure to conduct this as bad alignment might have occurred by transportation. Refer to “14. Coupling”.
  - b) Belt tension and Alignment of pulley (HH and HL type)  
Make sure to conduct this as loose belt or bad alignment of pulley might have occurred by transportation. Refer to “15. Belt”.
- (3) Grease-up
- If the manufacturing date of the motor and/or blower which need lubricating is before more than 2 months, lubricate them. Refer to “12. Bearing”.
- (4) Rotational direction
- Rotational direction should have been checked at the time of connection to the power line, but recheck by jogging the blower.
- Pay attention to the following when jogging the blower.
- a) Clean up the area around the blower for safety.
  - b) Fully close the valve.
  - c) Do not use a temporary power wiring. But if unavoidable, carefully operate switches.
- (5) Startup
- a) During the startup, large vibration can be observed at certain speed. It is due to specific resonance frequency of the blower and is not abnormal.
  - b) When the blower reaches to the rated speed, a noise with periodical sound can be heard. But this is due to surging phenomenon and is not abnormal noise.
- (6) Abnormal noise or vibration
- When abnormal noise or vibration is noticed, stop the blower. Refer to “appendix-1”.
- (7) Ex-surfing point (where surging disappears)
- If the blower runs in a range less than a certain volume, surging phenomena can be observed. The range varies by each blower, and also the surging range varies some by the condition of piping or location of air volume control valve. Never operate blower in surge, because blower in surge will not have stable performance and mechanical failure can be caused.
- Confirm the ex-surfing point during the test run, and record the values of valve opening and current on the point. These values should be used as the guideline for the lower limit on actual operation.
- (8) Use point and Rated point
- The use point is the value for the air volume and pressure in actual use by user and it is not necessarily be the rated point. The rated point is the values for air volume and pressure indicated on the blower name plate.

(9) Check of vibration

Record the value of vibration for various parts (especially the vibration of bearing) if a vibration meter is available. If the meter is not available, a touch and feel by hand for vibration will be a useful guide for future maintenance.

(10) Raised temperature at bearing

Measure a bearing temperature while the blower is continuously running near the rated point. Usually the temperature stabilizes after running 1 to 2 hours. But after lubricated, it may take several hours to stabilize.

(11) Completion of test run

It is recommended that all of checked items and measurement data are recorded for future maintenance and check.

## **10. Operation**

The blower is ready for use after the test run is completed. Note following points for safe operation.



### **Caution**

**If the inlet or outlet is open, make sure no person nor loose article are in their vicinity.**

### **10-1. Startup operation**

- (1) It is recommended that the air volume control valve is closed fully when starting up.
- (2) Open the valve to the use point as soon as completing the startup to avoid a surging.
- (3) If the air volume control valve is an electric control type and connected to starter unit, set the timer as short as possible so as to shorten the time for control valve to open to the determined position after the completion of startup.

### **10-2. Air volume adjustment**

- (1) Never operate the blower in surging range nor at the range exceeding the rated output (rated current) of the motor.
- (2) Open the air volume control valve to the use point and fix at there.
- (3) As current varies with conditions such as the air resistance, air pressure or temperature, if necessary, adjust the valve opening.
- (4) If the blower has to be used within the surging range due to broad air volume range, eliminate by increasing the air volume either into the system or to a bypass or vent.

## **11. Maintenance and Check**

It is recommended to conduct maintenance with a proper maintenance plan as good maintenance will prolong the life of the machine.

### **11-1. Routine check**

- (1) Is the air volume and pressure sufficient?
- (2) Is the motor running within the rated current?

- (3) Is there surging?
- (4) Is there any abnormal noise or vibration?
- (5) Is the room temperature too high?
- (6) Is the temperature of bearing or motor frame too high?
- (7) Is there any air leakage or oil leakage?

If abnormality is found, take actions referring to “Appendix-1 Troubleshooting”.

### 11-2. Monthly check

- (1) Check of lubrication
- (2) Check of loose bolts and nuts
- (3) Check and cleaning of belt
- (4) Cleaning of air filter (if any)

### 11-3. Overhaul

- (1) Interval

The overhaul interval varies with the environment of the location and usage conditions.

Determine the appropriate interval referring to the chart below.

Environment	Gas	Overhaul interval	
		> 12 hours / day	≤ 12 hours / day
Good	Normal air	2~3 years	3~4 years
Dusty / Humid	Normal air	1~2 years	2~3 years
	Other	Max. 1 year	Max. 1~2 years

Regarding motor, refer to the instruction manual of the motor.

- (2) Work of overhaul

Work	S	H	HL	HH
Adjustment or replace of shaft seal packing	○	○	○	○
Replace grease (*1)	-	○	○	○
Replace bearing (*2)	-	○	○	○
Cleaning of bearing box	-	○	○	○
Check and alignment of coupling	-	○	-	-
Replace coupling	-	△	-	-
Check and adjustment for belt tension and pulley alignment	-	-	○	○
Replace belt	-	-	○	○
Check the inside of blower	○	○	○	○
Clean the inside of blower	△	△	△	△
Re-balance of fan	△	△	△	△
Re-tighten bolt and nut	○	○	○	○

○: Mandatory

△: As needed

(\*1) The blower with sealed bearing does not need greasing.

(\*2) Every 2 years

## 12. Bearing

This section explains about blower bearings. For motor bearings, refer to the instruction manual of the motor. If the blower bearing needs lubricating, there is the greasing instruction plate on the blower.

Note: If the blower is a lubrication type, oil may ooze out of the shaft penetration part. This oil is from overflowed grease, it is normal.

### 12-1. Bearing

The Muto Wide Blower is equipped deep groove ball bearings and/or an angular contact ball bearing.

### 12-2. Grease

Current standard of the blower greases are as follows.

	H	HL, HH
Model	Shell Gadus S2 V125J 2 (S)	Multemp SRL
Manufacturer	Shell	Kyodo Yushi Co.,Ltd.
Temp. range	-25 ~ 120 °C	-50 ~ 150 °C

Note: Because grease may be changed for use condition or customer's request, confirm the name plate on the blower.

### 12-3. Lubrication

#### (1) Lubrication points

The blower equipped with lubrication type bearing has the lubrication point label which indicates the lubrication point.

Lubrication point label



#### (2) Lubrication procedure

Lubrication can be done during blower is running, but be careful for rotating object. When lubricating during blower is not running, rotate the shaft by hand.

Inject the grease using a grease gun.

#### (3) Lubrication Interval

Lubrication the blower bearing in every 750 hours. Following is lubrication interval.

	Operation time	
	More than 12 hours per day	12 hours per day
Lubrication Interval	Approx. 1 month	Approx. 2 month

#### (4) Grease amount for addition and replacement

The proper amount of grease will vary with bearing size. Refer to the name plate on the blower.

#### 12-4. Bearing temperature

The temperature at the surface of the bearing box shall be less than 90 degree C. and the temperature rise shall be less than 55 degree C.

The temperature will rise temporarily after lubricated, but it will stabilize within a few hours. If the temperature stays high for long time, it may be due to bad grease or bearing. Find the cause, and replace them if necessary.

#### 12-5. Bearing noise

Following is typical bearing noises. (Refer to "Appendix-1 Troubleshooting")

- Race noise ..... Sliding sound, not loud
- Gauge noise ..... Metallic sound of ball holder vibration
- Dropping balls noise ..... Clicking sound (at low speed when decelerating)
- Squeaking noise ..... High tone metallic sound
- Dent noise ..... Harsh sound like riveting
- Debris noise ..... Unstable in loudness and no periodicity
- Broken noise ..... Very loud

#### 12-6. Vibration

As the vibration appears most clearly at the bearing, it is recommended to touch to the bearing portion when conducting routine check, if available, using vibration meter.

The vibration should be 80 μm or less (peak to peak).

### 13. Shaft seal

The Muto Wide Blower is equipped with following either packing as shaft seal. At maintenance, confirm the type of the seal used the on the blower.

**⚠ Warning** Do not adjust or replace the packing without turning off the power.

Standard packing

- Three sheet packing
- Gland packing

#### 13-1. Three sheet packing

(1) Structure

This seal is made up of Three sheet packing and thin steel plate. The internal diameter of the thin plate is designed to be larger than that of Three sheet packing. This is that there is space which the packing get into when expanding.

Note: Three sheet packing is the product of Three Bond Co., Ltd.

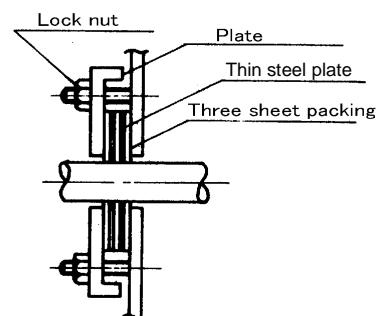

(2) Maintenance

This packing does not need daily maintenance and check-up as it shows little wear. Ensure the packing at overhaul, if necessary, and adjust or replace.

**13-2. Gland packing**

(1) Structure

The following figure is the typical structure of gland packing. The number of grand packing and the structure may vary from the blower. As to the seal performance, gland packing is better than Three sheet packing.

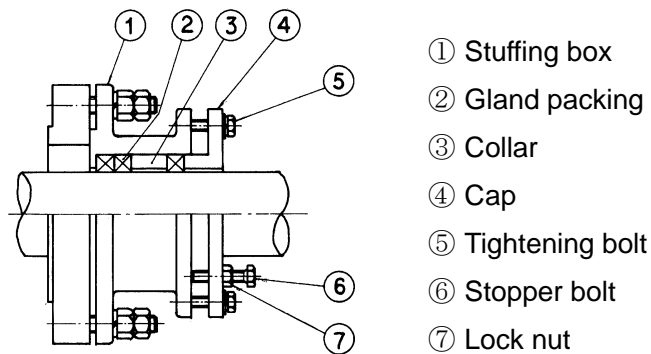

(2) Gland packing used in standard

Manufacturer ..... Nippon Pillar Packing Co.,Ltd.  
Model ..... Pillar 6501L  
Material ..... Carbon fiber + Teflon + Lubricant oil  
Feature ..... Dry operation is available with self-lubrication  
Minimal shaft wear by packing

(3) Maintenance

The gland packing does not need to be lubricated as self-lubrication. When the leak is excessive, adjust or replace the gland packing per following procedure. If the leak is excessive even after adjusting, gland packing ② should be replaced by a new one.

[Adjustment]

- a) After loosening lock nut ⑦, loosen stopper bolts ⑥ for one turn (Approx. 1mm). Tighten tightening bolts ⑤ evenly. If the shaft can be rotated lightly, loosen stopper bolts ⑥ for one turn and tighten tightening bolt ⑤ again.
- b) Rotate the shaft by hand and if it is felt a little heavy, stop adjusting and tighten stopper bolt ⑥ and lock nut ⑦.
- c) Rotate the shaft by hand until it is felt light so that gland packing ② can fit in the shaft, and then start the blower.

Note: If the blower is started before gland packing ② fit in the shaft, the shaft may be bend by large amount of frictional heat.

[Replacement]

- a) After loosen lock nut⑦, remove stopper bolts ⑥ and tightening bolts ⑤. And then move

cap ④ to the location at where old gland packing ② can be removed easily.

- b) Remove gland packing ② and collar ③.

Note: Record the number of gland packing ② at both sides of collar ③.

- c) After removing old packing, cut new packing to the size and install them into stuffing box ① in reverse order of removal. Make sure that the number of gland packing ② and location of collar ③ is correct.

Note: Cut gland packing ② in slant and locate the cuts evenly.

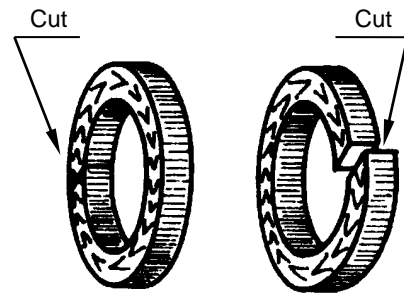

- d) After installing gland packing ②, place cap ④ and tighten tightening bolts ⑤ evenly. Screw-in stopper bolts ⑥ to cap ④ until touching to stuffing box ①. And then loosen stopper bolt ⑥ for one turn (Approx. 1mm).
- e) Tighten tightening bolts ⑤ to fix the cap ④. And then after tightening stopper bolts ⑥, tighten lock nuts ⑦.
- f) Rotate the shaft by hand until it is felt light so that gland packing ② can fit in the shaft, and then conduct the test run. If nothing found after running for 20 to 30 minutes, the replacement of gland packing is complete.

Note: Occasionally abnormal vibration is seen, but this is due to the fact that the packing is not fit to the shaft. The vibration shall diminish by repeating the start and stop for several times.

If the leak is excessive due to loose fit, tighten the packing referring to “[Adjustment]” above.

## 14. Coupling (H type)

The blower is equipped with flange type flexible coupling or gear coupling. Make sure which coupling the blower has.

**⚠ Warning** Do not disassemble, assemble, lubricate nor adjust the coupling without turning off the power.

### 14-1. Flange type flexible coupling

#### (1) Structure

This coupling meets JIS standards and is widely used. It does not need lubricating and is simple construction and easy to use.

The only consumable component on this coupling is the rubber bush ③ in the figure below. Because the life is approximately 1 year with continuous operation, it is recommended to replace the parts every year.

Note: The gap varies with the coupling size.

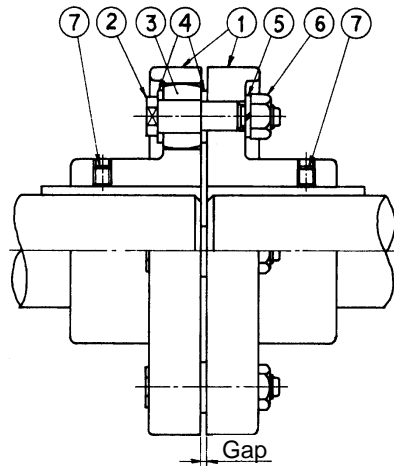

- ① Body
- ② Bolt
- ③ Rubber bush
- ④ Washer
- ⑤ Spring washer
- ⑥ Nut
- ⑦ Set Screw

Size	Gap (mm)
CL112	3
CL125	3
CL140	3
CL160	3
CL180	3
CL200	4
CL224	4
CL250	4
CL280	4

(2) Replacement procedure of rubber bush

Rubber bush ③ can be replaced without removing body ① from the shaft.

Remove bolts ②, nuts ⑥ and rubber bushes ③ from body ①. Replace with the new rubber bushes ③ and reassemble as they were.

**14-2. Gear coupling**

(1) Structure

This coupling needs to be lubricated. If lubricating is missed, the gear wears very quickly. And the life of the coupling may become short.

Note: The gap and plug size vary with the size of the coupling.

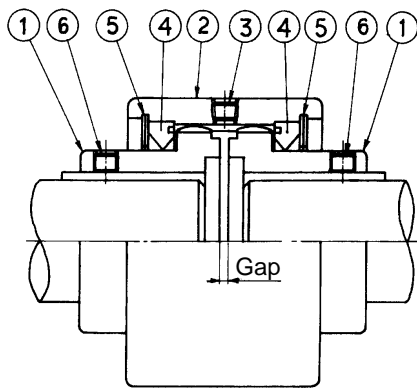

- ① Hub
- ② Unisleeve
- ③ Lubrication plug
- ④ Oil seal
- ⑤ Circlip
- ⑥ Set screw

Size	Gap (mm)	Plug
IUS-A8	2.5	NPTF 1/16
IUS-A10	2.5	NPTF 1/16
IUS-A12	2.5	NPTF 1/16
IUS-A20	3.2	NPTF 1/8
IUS-A25	4.8	NPTF 1/8

(2) Grease used in standard

Model	Shell Gadus S2 V125J 2 (S)
Manufacturer	Shell
Temp. range	-25 ~ 120 °C

(3) Lubrication procedure

**⚠ Warning** Do not lubricate the coupling without turning off the power.

- a) Remove the cover of the coupling, remove 2 lubrication plugs and position the coupling to 45

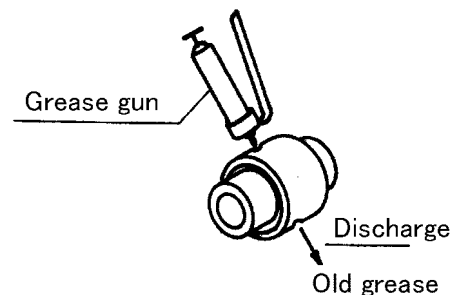

- degree angle. Inject the grease from the hole on the top. (refer to the figure above)
- Stop injecting when the new grease is discharged from the hole at the bottom. Tighten the plug firmly as it was. Wipe off excessive grease.
  - Reinstall coupling cover after finishing the grease-up

(4) Lubrication amount and Interval

The guideline of the lubrication amount and Interval are as shown on the following table.

Size	Amount (g)	Interval
IUS-A8	15	Every 6 months
IUS-A10	30	
IUS-A12	40	
IUS-A20	110	
IUS-A25	160	

[Disassembly]

- Remove circlip ⑤ from the ring groove by using a screw driver and small punched hole on the tip of circlip ⑤. (Refer to the figure on right)
- Slide unisleeve ② and remove oil seal ④ from the seal groove.
- Loosen the set screw ⑥, and then pull out hub ① using a puller. Do not hook the puller to the gear portion of hub ①.

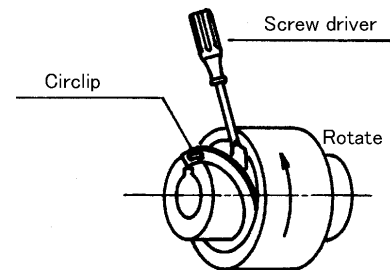

Good

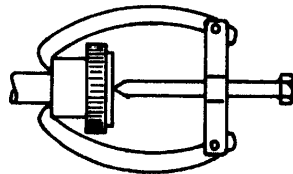

No good

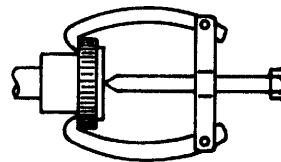

[Reassembly]

- Before reassembly, clean the parts.
- Insert circlip ⑤ and oil seal ④ to the shaft at first, and then install hub ① as heated up. After installing hub ① to the shaft, put sufficient amount of hardening sealant to the key groove to prevent the leakage from the groove.
- Align the tooth of both gears and set unisleeve ②.
- Insert oil seal ④ to the seal groove and install circlip ⑤ to the ring groove completely. If that is not perfectly installed, they may become loose during operation.
- Fill up with the grease.

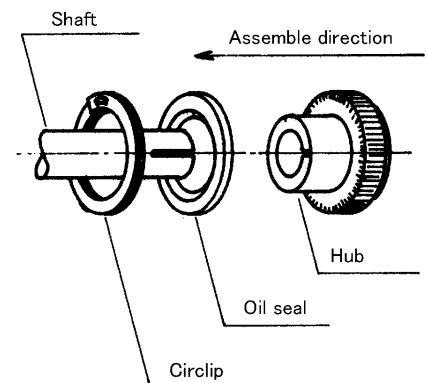

### 14-3. Alignment

#### (1) Tolerance

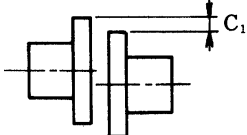
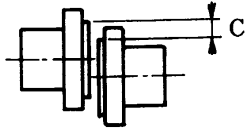
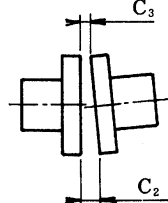
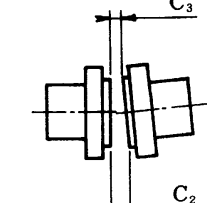
	Flange type flexible coupling	Gear coupling
Concentricity	 $C_1 \leq 7.5/100\text{mm}$	 $C_1 \leq 10/100\text{mm}$
Face	 $C_2 - C_3 \leq 7.5/100\text{mm}$	 $C_2 - C_3 \leq 10/100\text{mm}$
Gap between the faces	Refer to 14-1.	Refer to 14-2.

#### (2) Re-alignment

Base on the blower side for measuring the misalignment.

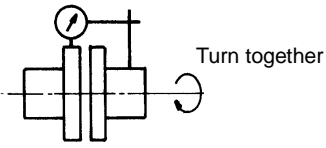
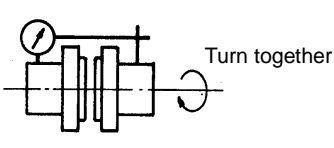
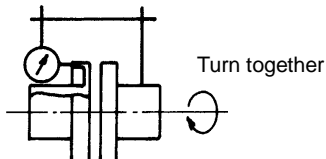
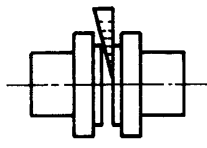
	Flange type flexible coupling	Gear coupling
Concentricity		
	Measure by means of dial indicator or straightedge.	
Face		
	Measure by means of dial indicator or taper gage.	

For the re-alignment, adjust the motor side using flat shims made of steel or brass sheet.

## 15. Belt (HL and HH type)

 **Warning** Turn the power off before adjusting belt tension or replacing belt.

Because the belt has initial elongation, the belt tension may decrease. The belt tension should be checked and adjusted before operating the Fan. The initial elongation practically stops after a few days beginning to use the Fan. During that time, the belt tension should be checked and adjusted every day.

It is no problem that powder of the belt comes out until the belt fit in with the pulley.

### 15-1. Maintenance

- (1) Is belt tension appropriate?
- (2) Is there slip due to oil or water on the belt or pulley?
- (3) Is there any damage or wear on belt or pulley?
- (4) Is the alignment right?

Check above items time to time. Clean, adjust or replace, if necessary.

If the blower is not used for long time, loosen the belt. When resuming, run the blower after checking corrosion or dust on pulley, adjusting belt tension and running in the blower.

When operating the blower, make sure to put belt cover. Belt cover is very useful for safety as well as preventing oil or water contamination.

### 15-2. Adjusting and Replacing

Following is instructive to adjust belt tension and/or to replace belt.

- (1) Remove belt cover.
- (2) Loose the old belt as loosening the nuts fixing the motor, remove the belt.
- (3) Install the new belt. If multiple belts are used, it is recommended to use "matched set" of which the circumference length is the same.
- (4) Adjust the parallelism and offset as putting a ruler on motor pulley and blower pulley, at the same time, adjust deflection as you give tension at the center of the span to the belt. (Fig.1 and 2)

Note: The deflection, the tension and belt No. are shown on the nameplate (BELT SPEC.) on the Blower.

- (5) Put back belt cover.

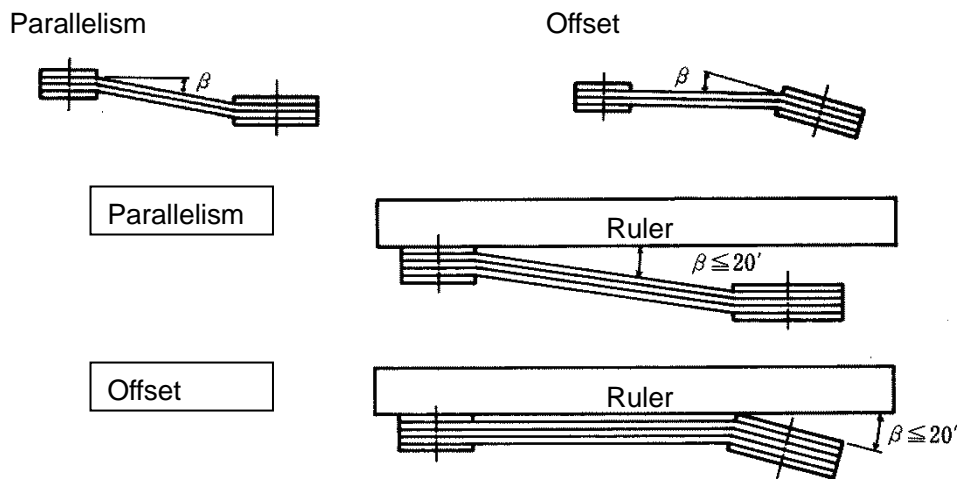

Fig.1 Parallelism and Offset

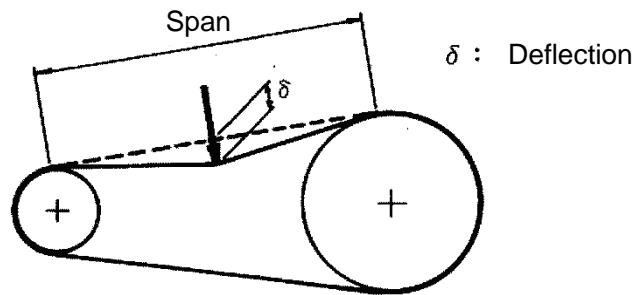

Fig.2 Tension

### 15-3. Storage

When storing belts as spare parts, be careful as follows:

- (1) Avoid direct sun light, and store in room temperature.
- (2) Hang on shelf or wall. (Do not place directly on the ground or floor.)
- (3) Do not store piling up or bending tightly.
- (4) Do not expose to oil or chemicals.

## **16. Motor**

Regarding motor, refer to the instruction manual of the motor.

## **17. Inquiry**

If you need to contact us regarding this product, please kindly inform us the information on the nameplate such as CAT. No. , PROD. No. , DATE. In case of troubles, inform us the broken portion, running time (days) and condition used and others additionally.

## **18. Limited Warranty**

The warranty period of this product is one year from the day of shipment unless otherwise specially agreed. Within the period, the malfunctions induced by defects of material or technical reasons will be repaired free of charge. But under following situation, this warranty will not apply to any products.

- (1) Malfunctions that occur past the warranty period
- (2) Malfunctions that occur due to inappropriate usage
- (3) Malfunctions or breakage due to inevitable event such as fire, severe weather, earthquake or such
- (4) By except us, the product has been repaired or modified.

We shall not be responsible for any incidental or consequential damages.

This warranty is valid only for the product used within Japan.

# Appendix-1 Troubleshooting

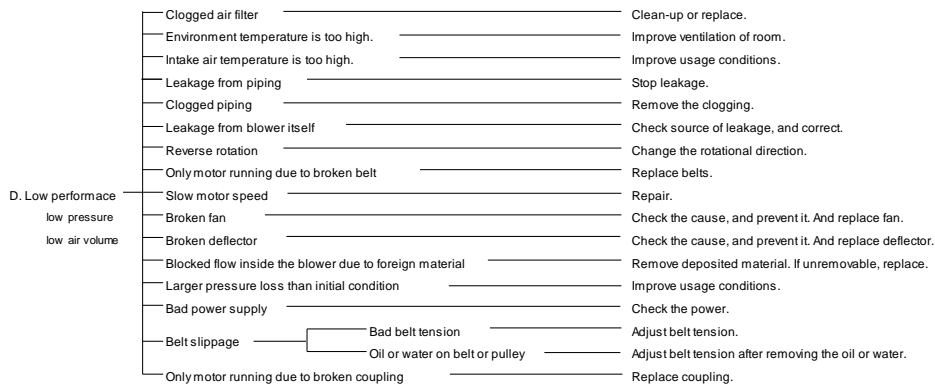
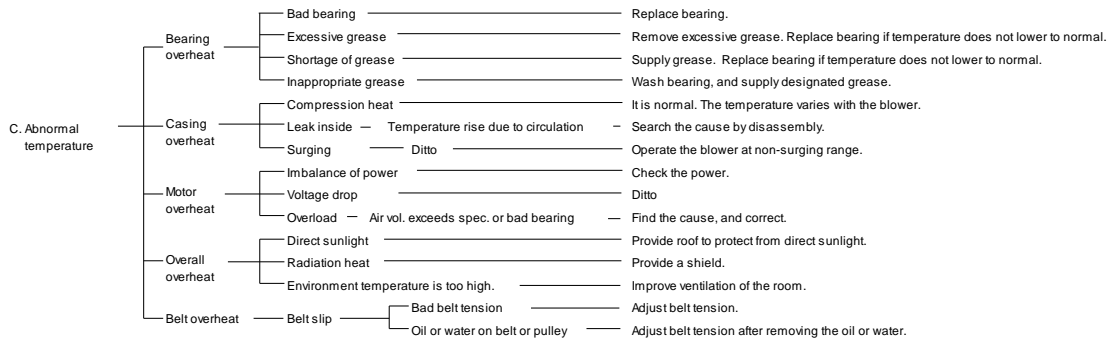
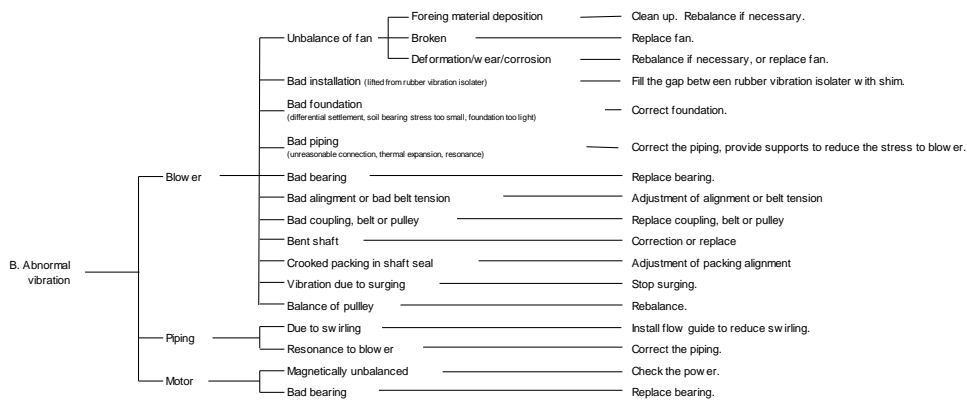
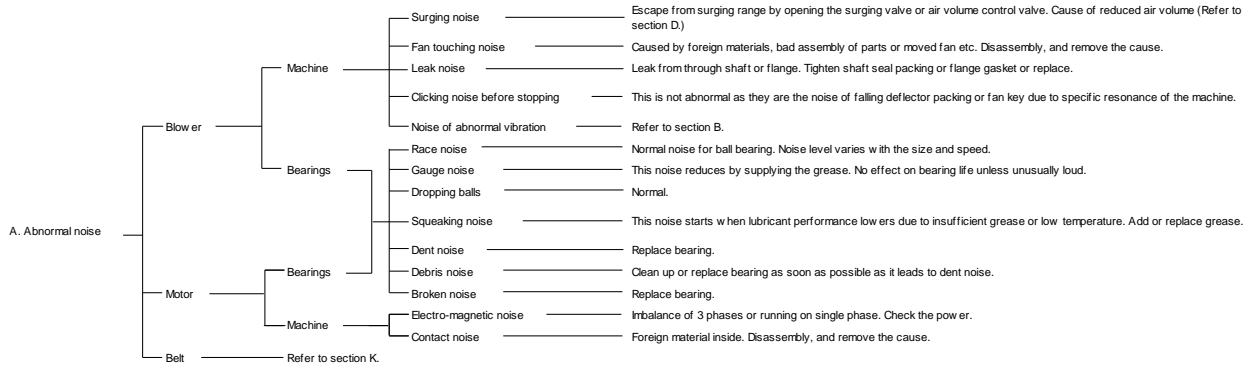

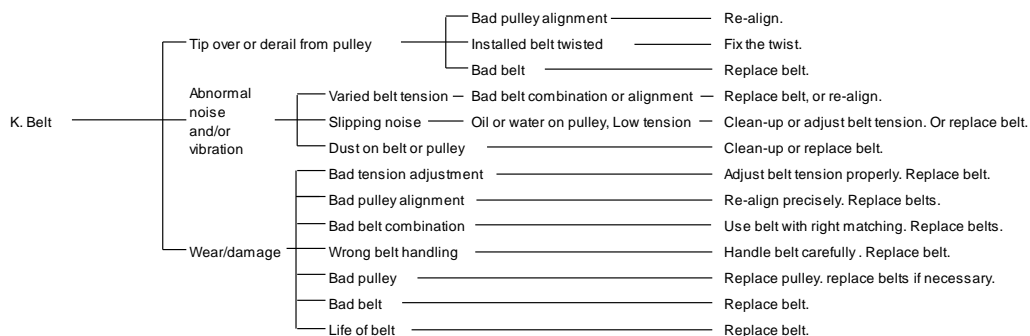
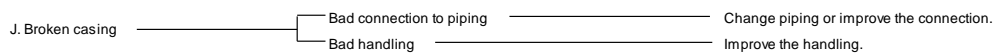
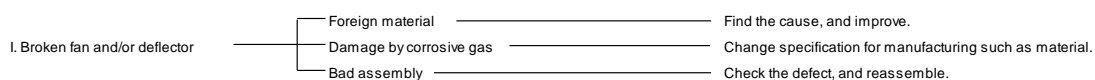
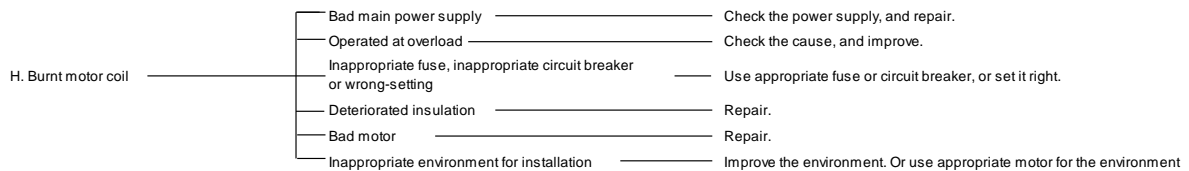
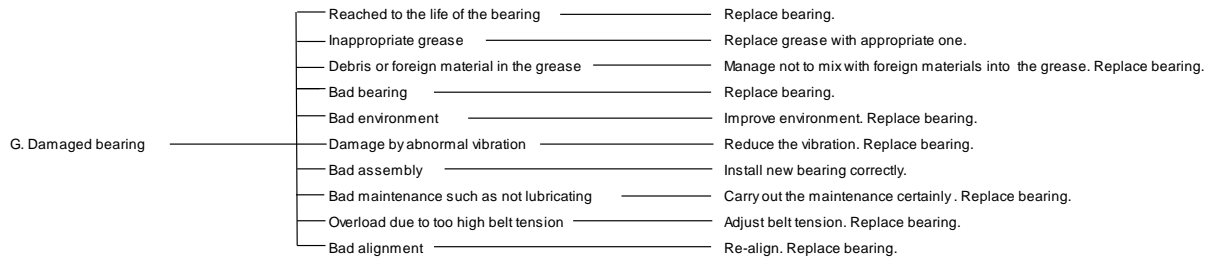
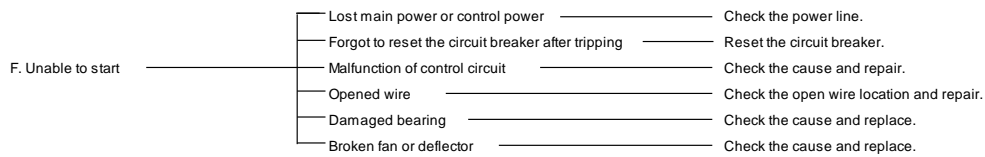
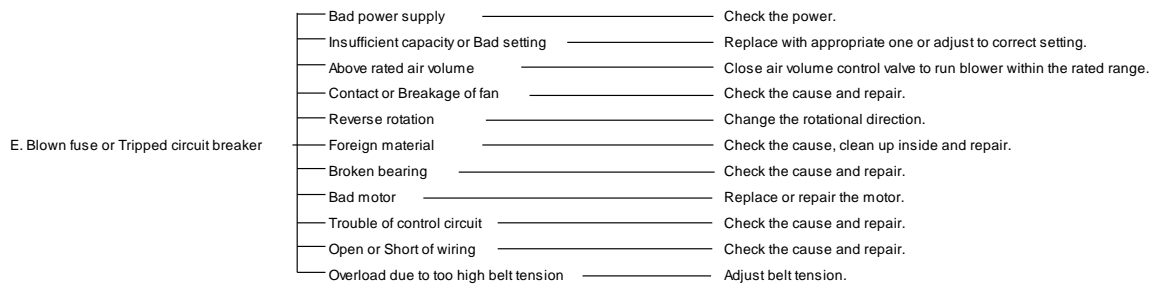

## Appendix-2 Structural drawing

S type

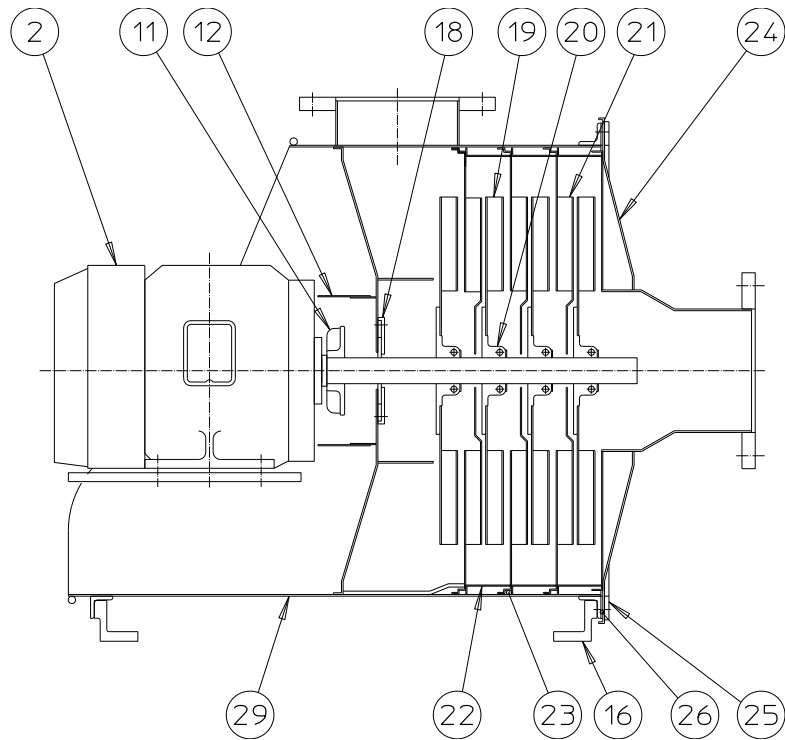

H type

Model: Foot

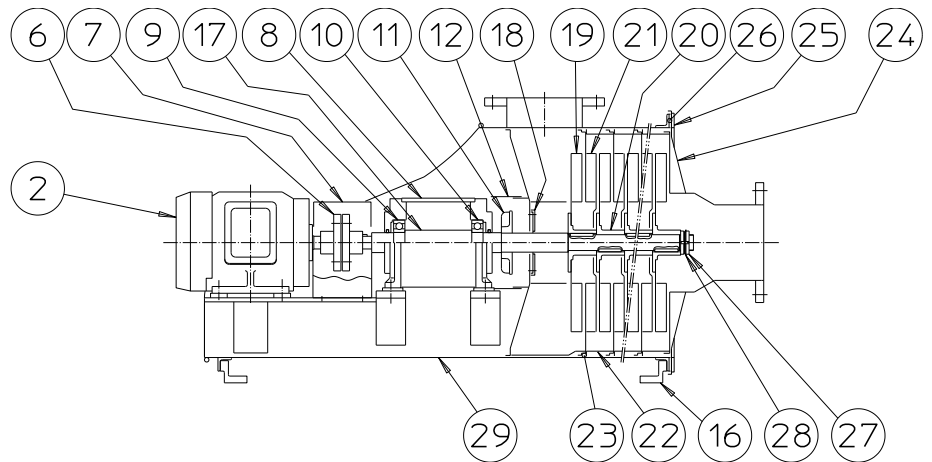

Model: Common base

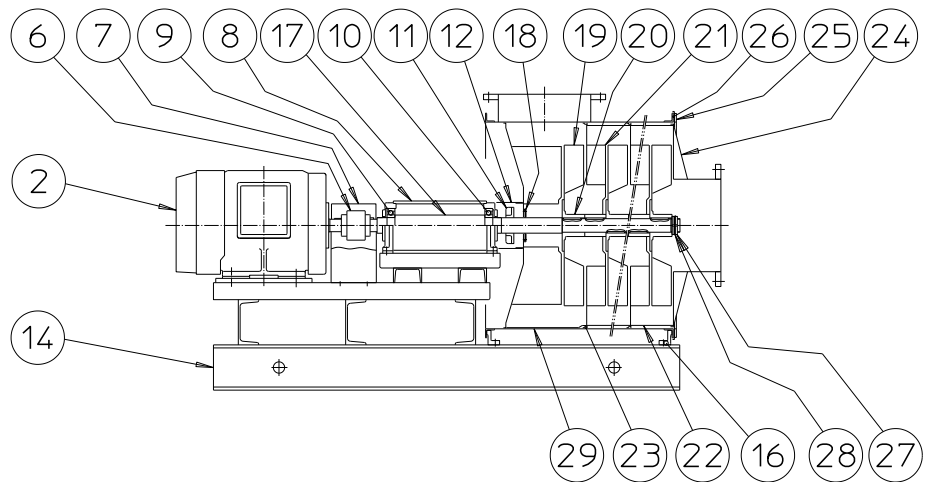

HL type

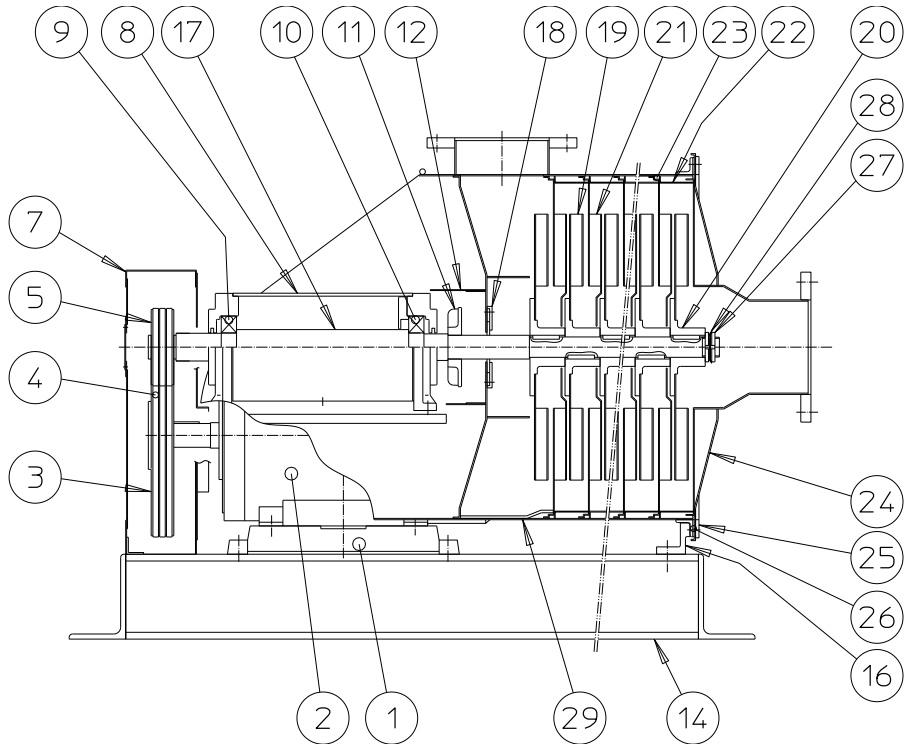

HH type

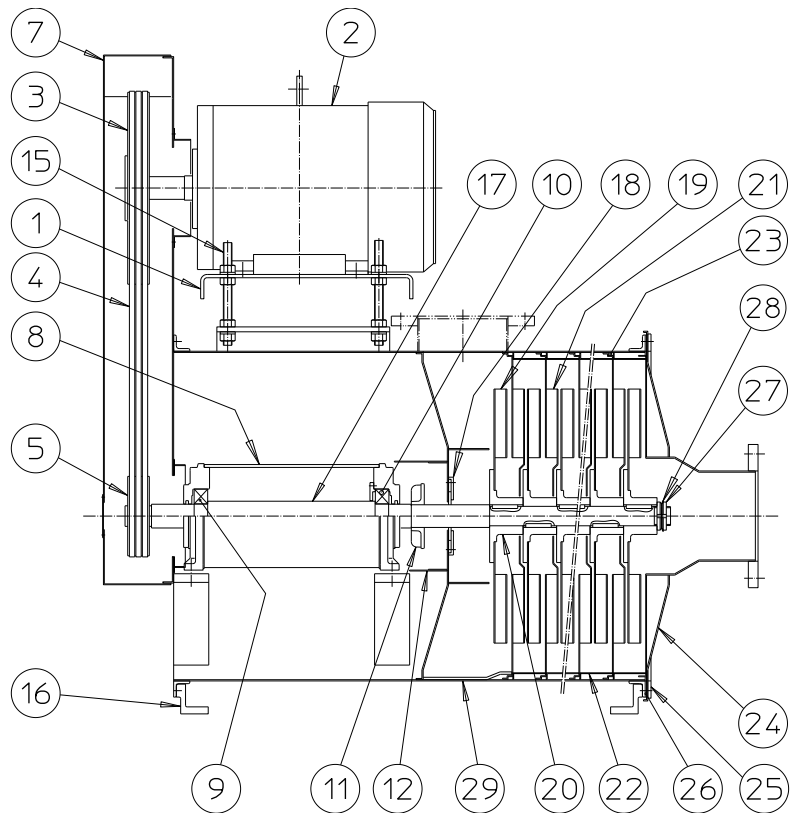

No.	Description
1	Motor base (HL) Motor plate (HH)
2	Motor
3	Motor pulley
4	Belt
5	Blower pulley
6	Coupling
7	Coupling cover (H) Belt cover (HL,HH)
8	Bearing box
9	Bearing on opposite load side
10	Bearing on load side
11	Cooling fan
12	Cooling fan cover
14	Base
15	Motor adjuster

No.	Description
16	Foot
17	Shaft
18	Shaft seal
19	Fan
20	Fan hub (united with fan)
21	Deflector
22	Spacer
23	Rope packing
24	End head
25	End head ring
26	End head gasket
27	Lock nut
28	Lock washer
29	Casing





## *Muto Products*

- Muto Wide Blower
- Muto Turbo Blower
- Muto Spencer Blower (Under technical license)
- Muto KF Blower
- Muto Scroll Blower
- Muto Central Vacuum System