

Muto Turbo Blower

MLB · GLB Series

200,300,330 type

Instruction Manual

Read this manual carefully before using the product.

Wrong operations deviating from this manual may lead to serious accidents or damages.

Keep this manual convenient location for easy access.



Muto Denki Corporation

Headquarters: 751, Nishi Hassaku-cho, Midori-ku, Yokohama, Kanagawa, Japan 226-0024

TEL: 81-45-932-2211, FAX: 81-45-932-2219

Osaka Branch: 4-14, Toyosaki 3, Kita-ku, Osaka City, Osaka, Japan 531-0072

TEL: 81-6-6372-1100, FAX: 81-6-6372-1797

Chino Plant: 11400-1107, Aza Harayama, Tamagawa, Chino City, Nagano, Japan 391-0011

TEL: 81-266-79-6071, FAX: 81-266-79-6074

web: <http://www.mutodenki.co.jp>

e-mail: sales@mutodeki.co.jp

Table of contents

1. Introduction	3
2. Safety precautions.....	3
3. Receiving Checkups	5
4. Transportation and Handling.....	5
5. Storage	5
6. Installation.....	5
7. Piping.....	5
8. Connection to Power and Test run	5
9. Precautions for Operation	6
10. Maintenance	6
11. Troubleshooting	7
12. Instruction for belt tension Adjusting and/or belt Replacing.....	8
13. Instruction for Disassembly and Reassembly	9
14. Consumables	11
15. Structural drawing.....	12
16. Motor	14
17. Inquiry.....	14
18. Limited Warranty	14

1. Introduction

Thank you for purchasing the Muto Turbo Blower.

This manual contains the information you need for handling, installing, operating and maintaining your new equipment correctly, to ensure trouble-free operation and long service life. Please read it thoroughly. After reading this manual, keep it in convenient place for easy access.

2. Safety precautions

Before starting any work such as handling, installing, operating and maintaining, carefully read this manual and all documents attached to the product for proper use. Use the product after thorough understanding of all product information, safety information and precautions.

In this manual, safety precautions are classified as "Warning" and "Caution".



This tag indicates that wrong operation or use may lead to fatal loss or serious injury.



This tag indicates that wrong operation or use may lead to human injury or loss of property.

Even the items under  may lead to serious results depending on the circumstances.

Those precautions include very important information and it is strongly recommended to follow them strictly.

Warning

(Place to install)

- The product with non-explosion proof type motor shall not be installed in explosive or inflammable atmospheres. Under those atmospheres, install the product with explosion proof type motor conforming to the degree of danger in that place. Otherwise injuries, explosions or fires may occur.

(Gas)

- Unless otherwise agreed separately, the product can handle only normal air. It is cannot be handled any other gas (explosive, toxic, corrosive, high temperature and so on), liquid or solid materials. Otherwise injuries, explosions or fires may occur.

(Wiring)

- Refer to the instruction manual of motor. Otherwise fires, electrical shocks or explosions may occur.
- Do not touch the wiring. Shut off the power before checking the wiring. Otherwise electrical shocks may occur.

(Operation)

- Do not get close to or look into the open inlet or outlet manifold during the product is running as it is very dangerous as follows.

Inlet : Clothing which you are wearing or a part of your body will be sucked in. As a result, injuries may occur.

Warning

Outlet : A strong wind or flown things may cause injuries.

- Do not insert finger(s) or hand(s) into the opening of the safety covers such as belt cover. Do not remove the safety cover during the product is running. Otherwise injuries may occur.
- Shut off the main power switch in case of power failure. Otherwise injuries may occur.

(Safety components)

- The product is shipped with metal mesh or pin attached to the inlet and outlet manifold, or otherwise the optional parts are included. If these parts are removed by some reason, take equivalent safety measures. Otherwise injuries may occur.

(Disassembly and Reassembly)

- Before disassembly and reassembly, make sure to shut off the main power and prevent power to be turned on. Otherwise injuries or electrical shocks may occur.

(Others)

- Follow the labels attached to the product. Otherwise serious results may occur.

Caution

(Transportation)

- Check the weight of the product with the specifications, drawing or catalogue before transportation, and be careful not to drop or tip over the product during transportation. Otherwise injuries or breakages may occur.

(Installation)

- Remove all of the inflammable from the product and its vicinity. Otherwise fires may occur.
- Ventilate the room to keep the ambient temperature below 40 deg. C. Otherwise motor-damage or bearing-damage may occur.

(Operation)

- If the product has high temperature label, do not touch the product with body or hand during the product is running. Take safety measures such as enclosing by fence or net. Otherwise burns may occur.
- Stop operating as soon as abnormality is found. Otherwise injuries, electrical shocks or burns may occur.
- Check rotational direction of the motor before operating. Otherwise breakages may occur.

(Disassembly and Reassembly)

- Disassembly and reassembly should be done by experts. Otherwise injuries or breakages may occur.
- Do not use the parts of the product for the use on other equipment. Do not use unauthorized parts for the product. Otherwise injuries or breakages may occur.

3. Receiving Checkups

Check if the products you have received are what have been ordered by referring to the order sheet, drawings, invoices, etc.

- (1) Check the nameplates on the blower and the motor, and confirm if it matches what have been ordered.
- (2) Count the number of products received, confirm if it agrees with what have been ordered.
- (3) Check whether there is any breakage during transportation.

4. Transportation and Handling

When transporting the blower, lift its base. Be careful not to give shocks to any parts of the blower.

5. Storage

If the blower is stored before installation, be careful as follows:

- (1) Store the blower in a room where ventilated, not humid nor dusty. Otherwise the blower may have some troubles.
- (2) Before operating the blower which has been stored for long period of time, check if the bearing and the insulation of the motor have no problem. And carefully check if the blower has no abnormality.
- (3) While the blower is stored, rotate the blower shaft several times by hand every month. If this procedure is not performed, the life of the bearing may become short.

6. Installation

The blower should be placed on the flat and rigid foundation with anchor bolt or vibration isolator. If there are gaps between the base and foundation, fill the gaps with thin steel sheets (shimming).

Clear some space to maintain the blower.

7. Piping

Use rubber sleeves or flexible joints to connect to piping to avoid unnecessary force to the blower and to isolate the vibration from the blower. If direct connection to piping is inevitable, do not give the force to the blower by dimensional tolerances, weight of piping, thermal expansion of piping, etc.

8. Connection to Power and Test run

- (1) Turn the blower shaft by hand to verify free rotation without rubbing or noise.
- (2) Check the belt tension and the pulley alignment referring to “12. Instruction for belt tension Adjusting and/or belt Replacing”.
- (3) Check the nameplates of blower and motor and confirm if they agree with the specification for power supply, then connect to power line under instruction by electrical engineer as per electric technical standards and wiring regulation.
- (4) Jog the blower and check the rotational direction is the same as the mark. If the rotational direction is opposite, change the wiring connection. The direction can be reversed by

interchanging any two line leads. If the blower is run continuously with reverse rotational direction, it cannot perform as specified and may lead to serious accident.

- (5) Running the blower, measure the electric current (average of each of 3 phase) of the motor. If it exceeds the rated current, use at below the rated current by adjusting the air volume with dumper and so on. After running for a while, if there is no abnormal vibration or noise, test run can be concluded. If any abnormality were found during test run, corrective action should be taken referring to "11. Troubleshooting".

9. Precautions for Operation

Before operating the blower, understand the following thoroughly.

- (1) Continuous use at small air volume will lead to fan durability problem.
- (2) The blower is designed to handle clean air. It cannot handle for air containing particulates and dust, corrosive gases nor inflammable gases. A standard model can handle the air in the range of -15 to 50 deg. C.
- (3) Because the belt has initial elongation, the belt tension may decrease. The belt tension should be checked and adjusted before operating the blower. The initial elongation practically stops after a few days beginning to use the blower. During that time, the belt tension should be checked and adjusted every day.

It is no problem that powder of the belt comes out until the belt fit in with the pulley.

10. Maintenance

The following maintenance is recommended to keep the blower in good condition.

- (1) Pay attention to ventilation to keep the ambient temperature in the range of -15 to 40 deg. C.
- (2) Pay attention to abnormal noise, abnormal vibration, abnormal temperature and air leakage. If abnormality is found, take actions referring to "11. Troubleshooting".
- (3) Periodically stop the blower, and check the tension and condition of the belt. If the tension is too low or the belt is damaged, adjust the tension or replace belt referring to "12. Instruction for belt tension Adjusting and/or belt Replacing".
- (4) If the blower has filter at the inlet, check the cleanliness of the filter periodically. Replace or clean the filter if and when the air filter is not clean, as it causes pressure loss. The filter can be washed by soaking into water or neutral detergents. (Wash it gently, do not rub or do not squeeze it.) Lay the cleaner side up to dry. It can be cleaned for a few times with this method.

11. Troubleshooting

The following table is for troubleshooting during test run and operation.

Trouble	Cause	What to do
Blown fuse or Tripped circuit breaker	Abnormal voltage or frequency	Consult with power company.
	Inappropriate capacity of power source equipment	Replace with appropriate one.
	Missing phase	Check wiring.
	Imbalanced voltage of phase	Consult with power company.
	Excessive voltage drop	Check the thickness and length of wiring.
	Excessive current	Reduce air volume by damper.
	Reversed rotation	Change wiring. (interchanging any two line leads)
	Fan touch	Repair.
	Water in the casing	Drain and take some preventive measure.
	Abnormality of bearing	Replace.
Insufficient air pressure or volume	Improper frequency	Consult with Muto.
	Too high ambient air temp.	Improve air ventilation of the room.
	Leakage or clogged piping	Check piping.
	Missing phase	Check wiring.
	Loose belt, damaged belt	Adjust belt tension, replace belt.
	Damaged fan, etc.	Repair.
	Reversed rotation	Change wiring. (interchanging any two line leads)
	Dirty or clogging air filter	Clean or replace.
	Lowered motor speed	Consult with Muto.
	Foreign material on the fan	Clean up.
Abnormal noise and/or vibration	Touching or broken fan or deflector	Repair.
	Reversed rotation	Change wiring. (interchanging any two line leads)
	Loose belt, damaged belt	Adjust belt tension, replace belt.
	Foreign material in the pulley groove	Get rid of foreign material.
	Bad pulley alignment	Adjust the alignment.
	Imbalance of fan	Fan cleaning. If vibration still remains, repair it.
	Bad bearing	Replace.
	Foreign material or water	Clean up and protect.
	Imbalanced voltage between phase	Consult with power company.
	Missing phase	Check wiring.
	Air leakage	Check piping and repair.
	Weight of piping or force induced by thermal expansion	Get rid of any force to the blower.

12. Instruction for belt tension Adjusting and/or belt Replacing

⚠ Warning Turn the power off before adjusting belt tension or replacing belt.

Following is instructive to adjust belt tension and/or to replace belt.

- (1) Remove the belt cover.
- (2) Loosen the holding bolts for the motor.
- (3) (When replacing) Bring the motor closer to the blower by the adjusting bolt of the motor-base, and remove the old belt.
- (4) (When replacing) Install the new belt. If multiple belts are used, it is recommended to use “matched set” of which the circumference length is the same.
- (5) Adjust the parallelism and offset as putting a ruler on motor pulley and blower pulley, at the same time, adjust deflection as you give tension at the center of the span to the belt. (Fig.1, 2 and Table 1)
- (6) Tighten the holding bolts to fix the motor.
- (7) Put back the belt cover.

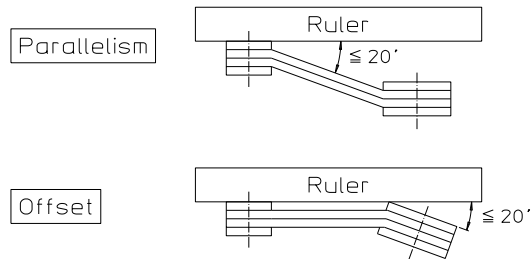

Fig.1: Parallelism and Offset

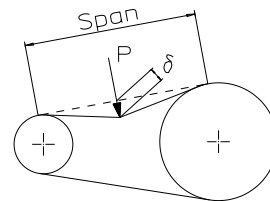

Fig.2: Tension

Table 1: Belt tension

Motor [kW]	δ [mm]	P [N/Belt]
1.5	5.5	10
2.2	5.5	13
3.7	5.5	18
5.5	5.5	20

13. Instruction for Disassembly and Reassembly

 **Warning** Turn the power off before disassembly and reassembly.

Following is instructive to disassemble and/or to reassemble the blower as referring to “15. Structural drawing”. (It is very difficult to explain all of details of the work perfectly in writing and by sketches. Therefore it is recommended to understand how the parts put together before disassembling and record the direction and order of the parts while disassembling.)

13-1. Disassembly

- (1) Remove the belt, and remove blower pulley ⑦. (See “12. Instruction for belt tension Adjusting and/or belt Replacing”)
- (2) Remove the bare blower from the base. Stand the blower on a stand with the inlet side up. (Be careful not to tip over the blower during the work.)
- (3) Remove bearing cover ③③.
- (4) Remove bearing nut ③① and bearing washer ③①.
- (5) Remove the screw holding bearing box ②⑧. Pull out both bearing ②⑨ and bearing box ②⑧ together. (Fig.3)
- (6) Pull off bearing ②⑨ from inlet side bearing box ②⑧. (Tapping bearing ②⑨ with a hammer-handle from backside will help for easy removal.) Pull off collar ②⑦ from shaft ①⑦.
- (7) Remove fan case fastening bolts ② as unfastening foot fastening nuts ③, and remove fan case (C) ②③ and foot ①.
- (8) Remove fan nut ②⑥ and fan washer ②⑤.
- (9) Remove fan ①⑨, deflector ②①, fan case (B) ②① through the last fan in this order.

Caution : Record the location of fan liner which might be left for fan location adjustment.

The catch portion of the fan case is filled with sealant, resulting difficult to disassemble the fan case. Be careful not to break the components.

- (10) Remove fan key ②②.
- (11) Remove bearing box ⑤ from fan case (A) ④. At this time, shaft ①⑦ should come off together with bearing box ⑤.
- (12) Remove cap ⑥.
- (13) Lay a wood-block on the floor, and stand shaft ①⑦ on top of-it in an upright position. (Fig.4)
- (14) Remove bearing box ⑤ from bearing ①⑤ by tapping outside uniformly with plastic hammer.
- (15) Remove bearing nut ①③ and bearing washer ①④.
- (16) Remove bearing ①⑤ from the shaft ①⑦ using a puller.

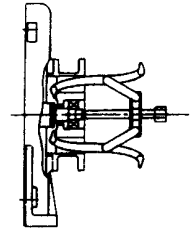

Fig.3

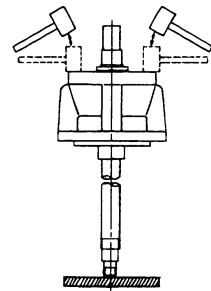

Fig. 4

13-2. Cleaning

Clean the disassembled parts. (For the parts in the bearing portion, clean thoroughly with washing solvents.) Visually inspect the parts.

13-3. Reassembly

Reassembly is basically the reversed order of disassembly.

- (1) Press bearing ⑮ onto shaft ⑰ until seated against the shoulder. (Fig.5)
- (2) Install bearing washer ⑭ and bearing nut ⑬.
- (3) Press bearing ⑮ into bearing box ⑤.
- (4) Install cap ⑥.
- (5) Install bearing box ⑤ onto fan case (A) ④.
- (6) Install fan key ⑳.
- (7) Assemble fan ⑲, deflector ㉔ and fan case (B) ㉑ through the last fan in this order.

Note : put on sealant between fan cases as necessary.

Sealant : Silicon sealant 5211 (by Threebond) or equivalent.

- (8) Install fan nut ㉖ and fan washer ㉕.
- (9) Install fan case (C) ㉓ and foot ① as lightly tighten fan case fastening bolts ② and foot fastening nuts ③.
- (10) Install bearing box ㉘ onto fan case (C) ㉓.
- (11) Press bearing ㉙ onto shaft ⑰ and into bearing box (inlet side) ㉘ until seated against the shoulder. (Fig.6)
- (12) Install bearing washer ㉚, bearing nut ㉛ and bearing cover ㉜.
- (13) Put back the blower on the base. After adjusting at foot ① and fan case (C) ㉓ to eliminate gaps, tighten firmly fan case fastening bolts ② and foot fastening nuts ③.
- (14) Install blower pulley ⑦ as heated up between 100 to 150 deg. C.

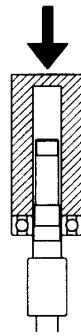

Fig. 5

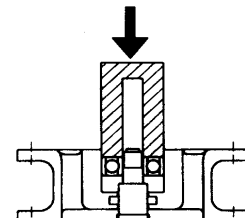
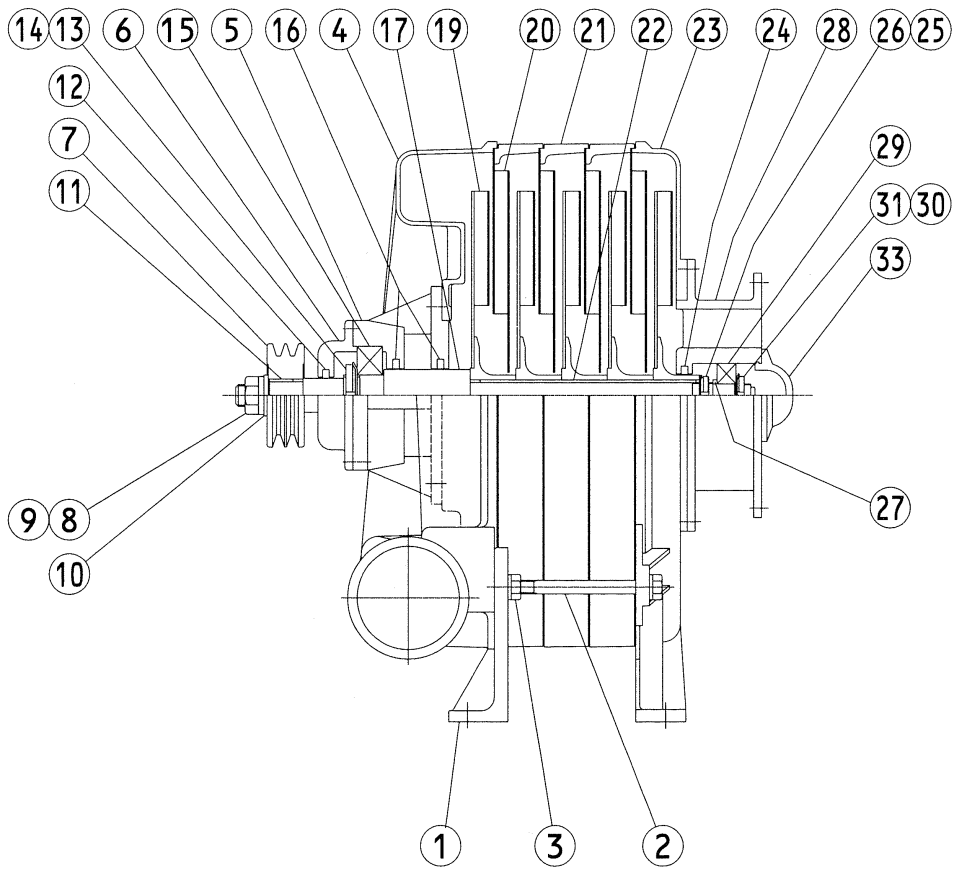

Fig. 6

14. Consumables

Model		Belt #		Belt Qty.	Bearing	
		50Hz	60Hz		Outlet side	Inlet side
MLB-203(225)	GLB-205(225)	3VX-475	3VX-475	2	6306 VVC3	6303 VVC3
MLB-203(240)	GLB-205(240)	3VX-475	3VX-500			
MLB-303(210)	GLB-305(210)	3VX-475	3VX-475			
MLB-303(225)	GLB-305(225)	3VX-475	3VX-475			
MLB-303(240)	GLB-305(240)	3VX-475	3VX-500			
MLB-503(255)	GLB-505(255)	3VX-500	3VX-500			
MLB-503(270)	GLB-505(270)	3VX-500	3VX-500			
MLB-503(285)	GLB-505(285)	3VX-500	3VX-530			
MLB-503(300)	GLB-505(300)	3VX-530	3VX-530			
MLB-233(150)	GLB-233(150)	3VX-450	3VX-450			
MLB-233(165)	GLB-235(165)	3VX-450	3VX-450			
MLB-233(180)	GLB-235(180)	3VX-450	3VX-475			
MLB-333(180)	GLB-335(180)	3VX-450	3VX-450			
MLB-333(195)	GLB-335(195)	3VX-450	3VX-475			
MLB-333(210)	GLB-335(210)	3VX-475	3VX-475			
MLB-533(225)	GLB-535(225)	3VX-475	3VX-500			
MLB-533(240)	GLB-535(240)	3VX-500	3VX-500			
MLB-533(255)	GLB-535(255)	3VX-500	3VX-500			

15. Structural drawing



No.	Description	Qty.		
		MLB-203 GLB-205	MLB-303 MLB-503 GLB-305 GLB-505	MLB-233 MLB-333 MLB-533 GLB-235 GLB-335 GLB-535
1	Foot	1	1	1
2	Fan case fastening bolt	4	4	4
3	Foot fastening nut	2	2	2
4	Fan case (A)	1	1	1
5	Bearing box (outlet side)	1	1	1
6	Cap	1	1	1
7	Blower pulley	1	1	1
8	Pulley nut	1	1	1
9	Spring washer	1	1	1
10	Washer	1	1	1
11	Pulley key	1	1	1
12	Felt ring 38X25X5	1	1	1
13	Bearing nut 06	1	1	1
14	Bearing washer 06	1	1	1
15	Bearing 6306VVC3	1	1	1
16	Felt ring 53X38X5	2	2	2
17	Shaft	1	1	1
18	—	-	-	-
19	Fan	3	5	3
20	Deflector	2	4	2
21	Fan case (B)	1	3	1
22	Fan key	1	1	1
23	Fan case (C)	1	1	1
24	Felt ring 43X30X5	1	1	1
25	Fan washer 19	1	1	1
26	Fan nut 19	1	1	1
27	Collar	1	1	1
28	Bearing box (inlet side)	1	1	1
29	Bearing 6303VVC3	1	1	1
30	Bearing washer 03	1	1	1
31	Bearing nut 03	1	1	1
32	—	-	-	-
33	Bearing cover	1	1	1

16. Motor

Regarding motor, refer to the instruction manual of the motor.

17. Inquiry

If you need to contact us regarding this product, please kindly inform us the information on the nameplate such as CAT. No. , PROD. No. , DATE. In case of troubles, inform us the broken portion, running time (days) and condition used and others additionally.

18. Limited Warranty

The warranty period of this product is one year from the day of shipment unless otherwise specially agreed. Within the period, the malfunctions induced by defects of material or technical reasons will be repaired free of charge. But under following situation, this warranty will not apply to any products.

- (1) Malfunctions that occur past the warranty period
- (2) Malfunctions that occur due to inappropriate usage
- (3) Malfunctions or breakage due to inevitable event such as fire, severe weather, earthquake or such
- (4) By except us, the product has been repaired or modified.

We shall not be responsible for any incidental or consequential damages.

This warranty is valid only for the product used within Japan.

— MEMO —

A series of horizontal dashed lines for writing.

Muto Products

- Muto Wide Blower
- Muto Turbo Blower
- Muto Spencer Blower (Under technical license)
- Muto KF Blower
- Muto Scroll Blower
- Muto Central Vacuum System